

Thank you for selecting a DuctSox fabric air dispersion system. This Guide should be helpful for installing all DuctSox systems manufactured for a suspended H-Track Suspension System (only).

Sections of DuctSox will be labeled, assembled, bagged and boxed for shipping. More complicated systems will include a CAD detail of the system identifying which DuctSox components are in each package. Depending on the size of a project or order, the DuctSox system will be shipped by common courier in "DuctSox" boxes. All orders including out H-Track - or - larger DuctSox orders will shipped in crates by freight carrier.

THE BASIC STEPS OF INSTALLATION INCLUDE:

- 1: Prepare Metal Outlet Collar for Fabric Connection
- 2: Identify Cable Locations / Install Supports & Cable
- 3: Install and Assemble DuctSox Components
- 4: Start Up AHU / Adjust DuctSox Fitment
- 5: Balance Airflow / Final Filter (if needed)

Step



METAL OUTPUT COLLAR CONNECTION

- DuctSox are mfg. 1/2" larger than specified to fit over metal duct.
- Collar length should be 6"-10" for secure fabric attachment.
- Edge guard (provided) should be installed on the edge to reduce fabric wear.

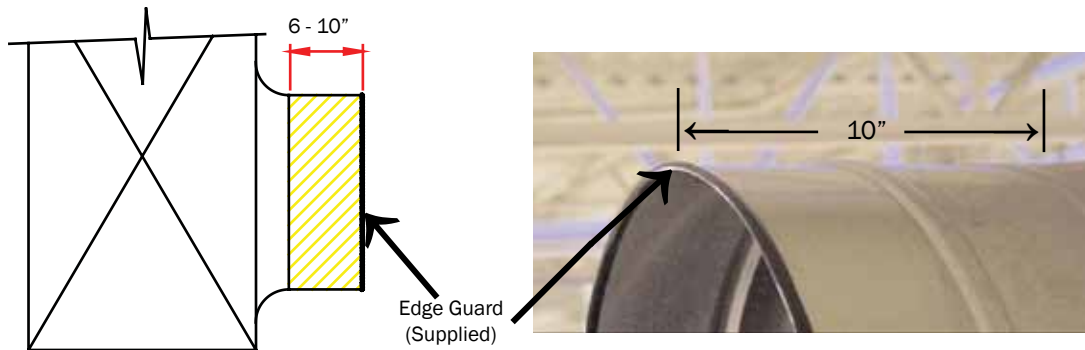

Step



LOCATE CABLE ANCHORS / COMPONENTS

Suspended H-Track System includes anodized aluminum track and assembly and suspension components. Gripper self locking wire rope grips help reduce installation time.

All components are available in 316.S/S for caustic applications.

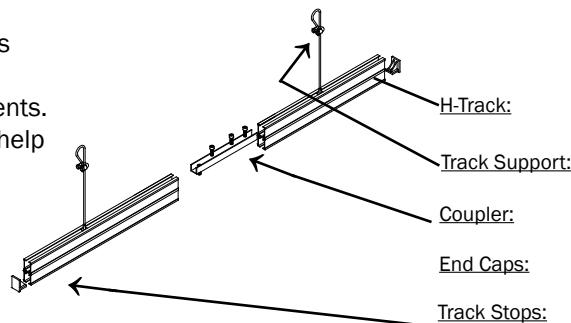

- 10' sections, radius sections available
- Install every 5-8 ft along track, Std. 5 ft Length (10', 15', 30' available)
- 6" long, 4 set screws, install as shown
- 1 per Track End, Secure w/ screw
- 1 per straight run, install at end to secure last snap on DuctSox in tension

2 INSTALL TRACK & COMPONENTS

Identify H-Track location and install Supports as required. 2 Row is required for 32" dia. and larger. Secure Cable Drops to track by tightening the double nut on the threaded drop support. Release Gripper using supplied tool to ease elevation adjustments.

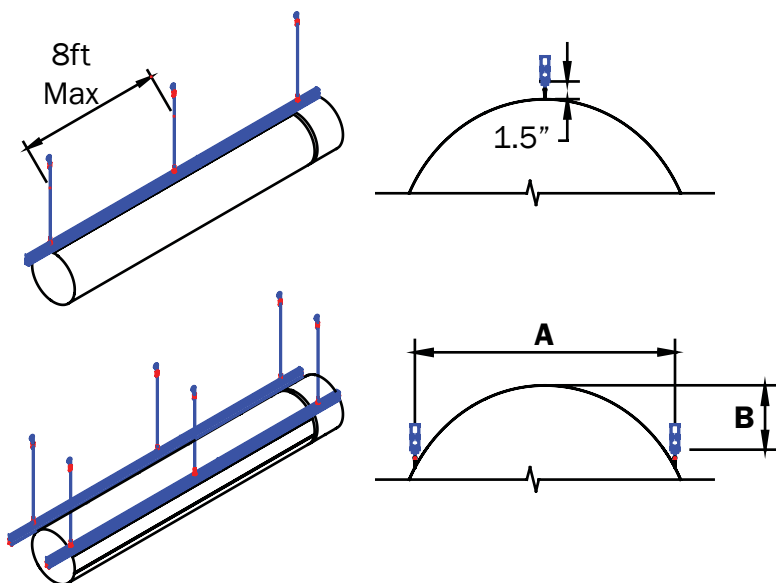

Dia.	A	B
12	10.4	1.5
16	13.8	2.5
20	17.4	3.5
24	20.8	4.5
28	24.2	5.5
32	27.8	6.5
36	30.2	7.5
40	34.6	8.5
44	38.2	9.5
48	41.6	10.5
52	45	11.5
56	48.4	12.5
60	52	13.5
64	55.4	14.5
68	58.8	15.5
72	62.4	16.5

Note:

DuctSox Tee fittings are available in Flat on Top, Concentric or Flat on Bottom. When determining track location, confirm fitting alignment to ensure proper track elevation.

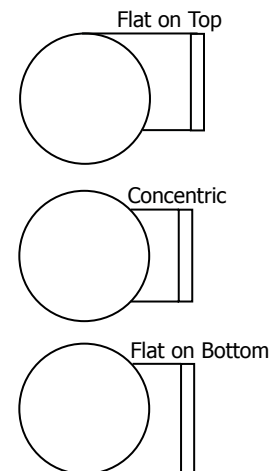

Support around fabric fittings may require additional track supports. For "T" fittings, Track run may need to be cut out and supported (as shown).

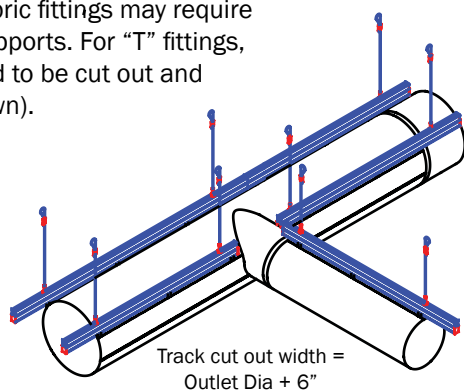

Include at least one support per radius section.

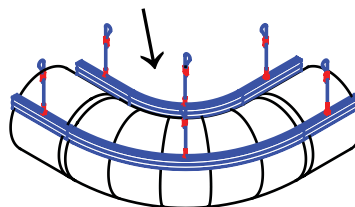

Cable Track Supports provided include a locking stud end and Gripper Quick Connect to ease installation.

Gripper Detail:

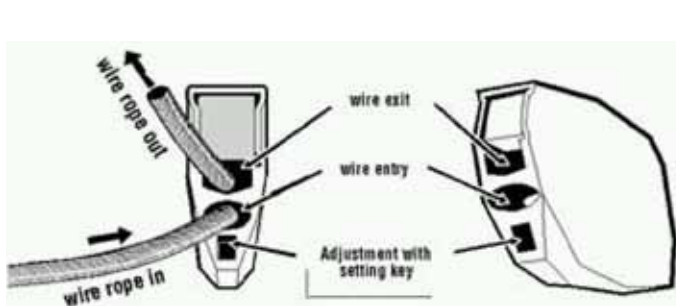

3

DUCTSOX FABRIC INSTALLATION

- Do not install DuctSox system until the building construction is completed and site is clean.
- Confirm centerline dimensions before unpacking and installing the DuctSox.
- During installation, use caution in all steps to keep the DuctSox clean.

Larger systems may be packaged separately. Each package will include a CAD detail revealing which sections are included in the package. Each piece includes a label on each zipper which includes diameter, length and piece number of that particular section.

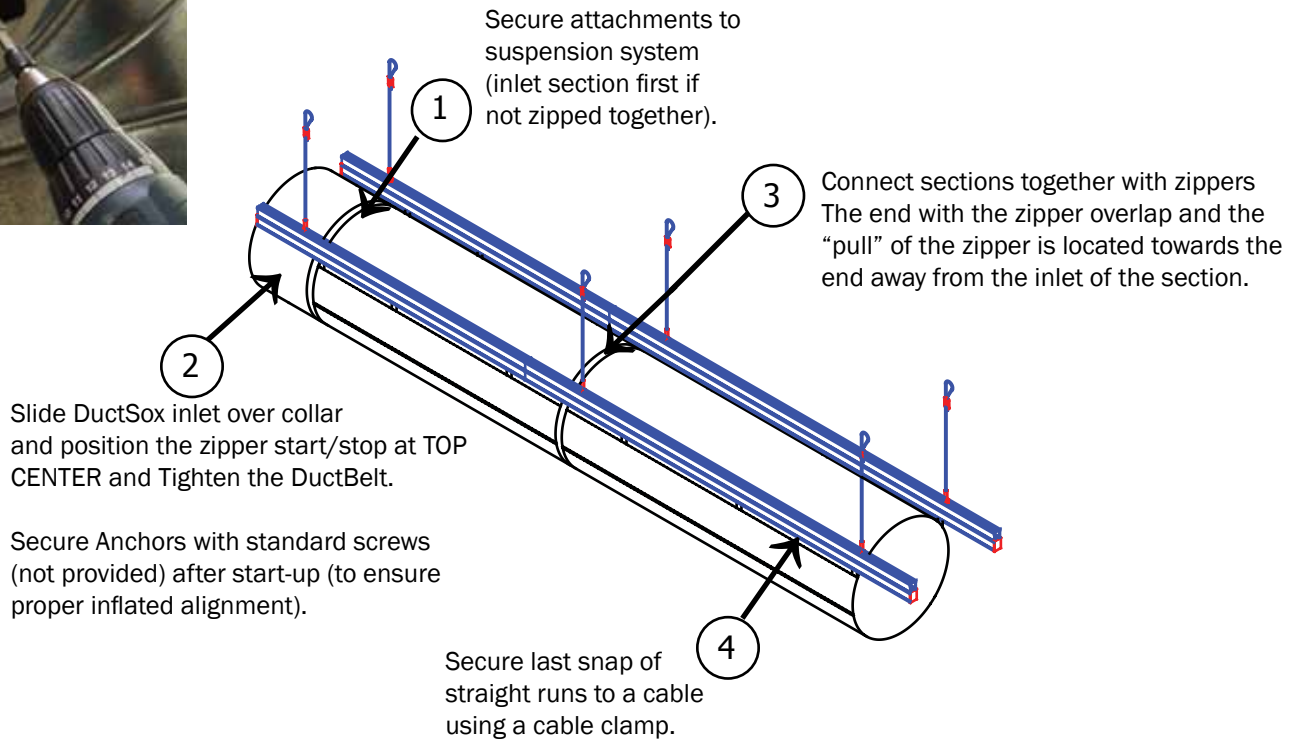

4

START UP

Turn on the AHU and inflate DuctSox System. Check all snaps and sections to ensure system is inflating properly. If required - move snaps to eliminate puckering at binding locations. If lengths do not fit properly - contact the factory to coordinate rework to ensure proper fit.

Once system is properly adjusted, deflate the system, pull the last snap in each straight section and secure tension using track lock (will reduce inflation "popping"). If the system includes elbows - secure the last snap before elbow(s).

***Track locks are provided to secure snaps.**



AIR BALANCING

System must be balanced to design CFM and static pressure immediately after installation. Most DuctSox systems include a zipper at the inlet location for easy access to monitor flow.

If the fabric is fluttering after balancing, please contact the factory immediately. Solutions to the fluttering include adjusting the Adjustable Flow Device (AFD), adding AFD's or other tasks that would result in laminar airflow.

FILTRATION / DUCTSOX FINAL FILTER

If included, a DuctSox Final Filter will be provided assemble with the DuctSox system and should be positioned at the first zipper at the inlet of the DuctSox run. If the Equipment / fabric duct is going to be running during construction, a Merv 8 construction filter may be helpful in reducing build up of dust / dirt.

If the system becomes dirty/soiled during installation, please coordinate a proper cleaning prior to completion. Exterior surface dirt can - most frequently - be blown off using a combination of a brush and compressed air.

LAUNDRY INSTRUCTIONS

Sedona-Xm, TufTex, Verona, DuraTex, Microbe-X & Stat-X fabrics:

- Remove system and break down into sections
- Turn Soiled side out, soak in cold water for 30 minutes
- Wash cold gentle cycle
- Rinse thoroughly (repeat cycle if water / DuctSox still soiled)
- Drip-dry or no heat tumble dry

PolyTex fabric (cannot launder)

- Remove DuctSox, spray clean with hose / water source.

If any questions arise regarding the installation of your DuctSox system,
please do not hesitate to consult your support team at
(866) DuctSox (382-8769).

DUCTSOX[®]

Fabric Duct Ventilation Products

9866 Kapp Court
Dubuque, IA 52068
www.ductsox.com