

Thank you for selecting a DuctSox fabric duct ventilation system. This Guide should be helpful for installing all DuctSox systems manufactured for a Tension Cable Suspension System (only). Tension cable suspension components are the most popular suspension method for DuctSox systems.

Sections of DuctSox will be labeled, assembled, bagged and boxed for shipping. More complicated systems will include a CAD detail of the system identifying which DuctSox components are in each package. Depending on the size of a project or order, the DuctSox system will be shipped by common courier in "DuctSox" boxes. All orders including our H-Track or a large amount of DuctSox may be shipped in crates by freight carrier.

**THE BASIC STEPS OF INSTALLATION INCLUDE:**

- 1: Prepare Metal Outlet Collar for Fabric Connection
- 2: Identify Cable Locations / Install Supports & Cable
- 3: Install and Assemble DuctSox Components
- 4: Start Up AHU / Adjust DuctSox Fitment
- 5: Balance Airflow / Final Filter (if needed)

Step

**1**

**METAL OUTPUT COLLAR CONNECTION**

- DuctSox are mfg. 13mm larger than specified to fit over metal duct.
- Collar length should be 150-250 mm for secure fabric attachment.
- Edge guard (provided) should be installed on the edge to reduce fabric wear.

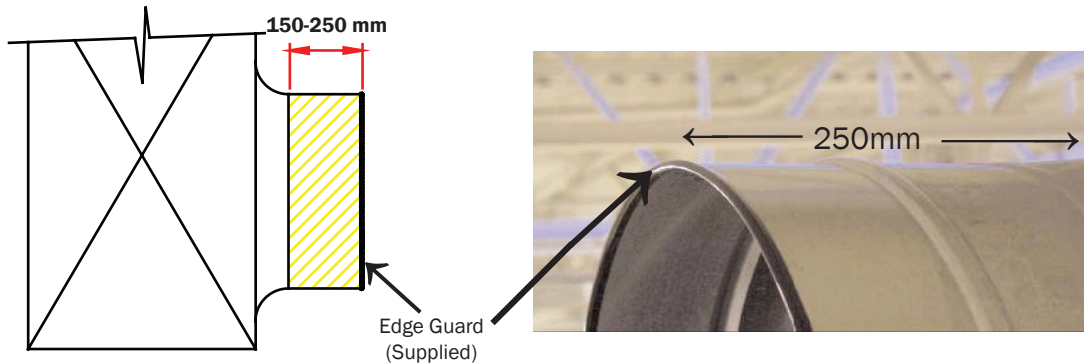

Step

**2**

**LOCATE CABLE ANCHORS / COMPONENTS**

Tension Cable System includes 3 mm cable and hardware as shown (length = DuctSox length + 6 M.)

LENGTHS < 15 M	LENGTHS > 15 M
<p>Hardware kit includes: 1 Turnbuckle (150mm draw), 2 Eyebolts, 4 Cable Clamps and 2 Thimbles Cable Length = DuctSox Length + 6 M (per straight)</p>	<p>Hardware kit includes: 2 Turnbuckles (150mm draw), 2 Eyebolts, 4 Cable Clamps and 2 Thimbles Cable Length = DuctSox Length + 6 M (per straight)</p>

# 2

## CABLE LOCATION/ INSTALLING CABLE

Install Cable end supports and as required. 2 Row is required for 810mm dia. and larger. Construct any support brackets for 68kg max. cable tension. To prevent "sagging" - install provided cable support kits (cable & Gripple) every 9m or as needed.

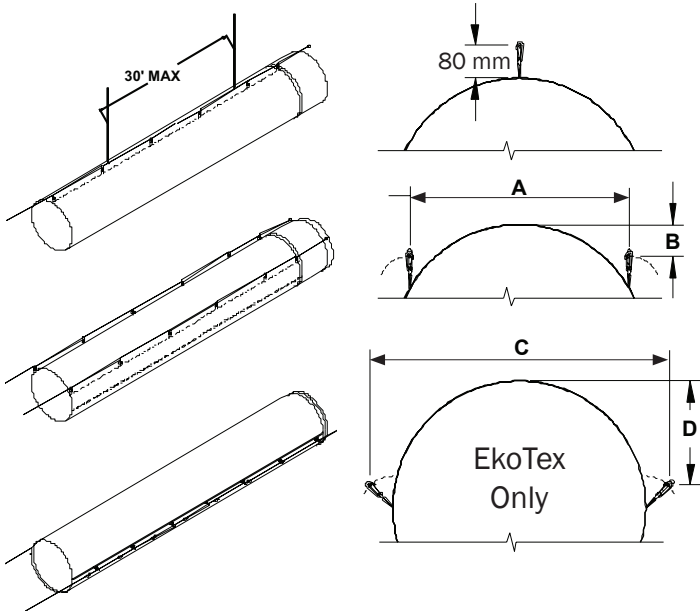

Dia.	A	B	C	D
300	260	0	355	130
410	330	25	456	180
510	440	50	557	230
610	530	75	658	280
710	610	100	759	330
810	710	125	860	380
910	770	150	961	430
1020	880	175	1062	480
1120	970	200	1163	530
1220	1060	225	1264	580
1320	1140	250	1365	630
1420	1230	275	1467	680
1520	1320	300	1568	730
1630	1410	325	n/a	n/a
1730	1490	350	n/a	n/a
1830	1580	375	n/a	n/a

For 360mm - average between 300 & 410mm  
A=3690mm spacing / B = 13mm

### Note:

DuctSox Tee fittings are available in Flat on Top, Concentric or Flat on Bottom. When determining cable location, confirm fitting alignment to ensure proper track elevation.

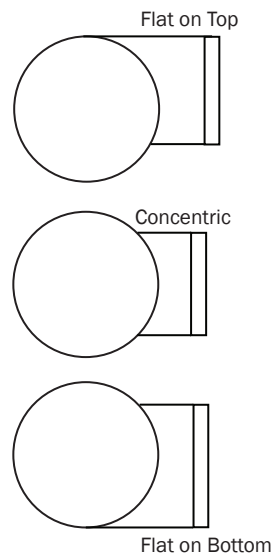

Fittings may require additional cable supporting brackets for elbows and take-off's. For best results, verify details on all fittings before determining cable end locations.

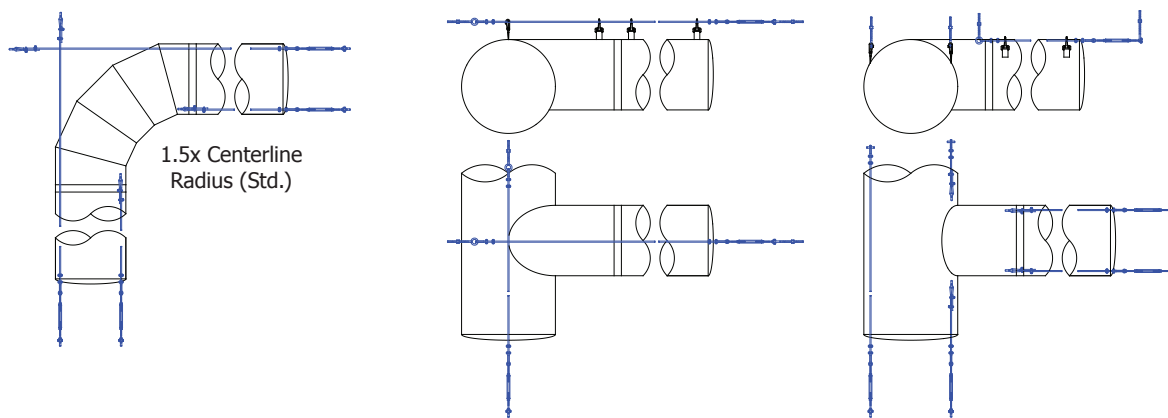

Intermediate Cable Drop supports provided include loop end and Gripple Quick Connect to ease installation.

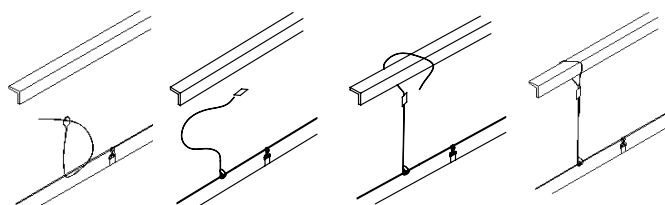
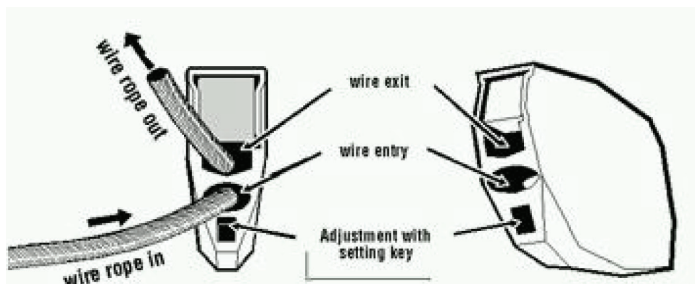

# 3

## DUCTSOX® FABRIC INSTALLATION

- Do not install DuctSox system until the building construction is completed and site is clean.
- Confirm centerline dimensions before unpacking and installing the DuctSox.
- During installation, use caution in all steps to keep the DuctSox clean.

Larger systems may be packaged separately. Each package will include a CAD detail revealing which sections are included in the package. Each piece includes a label on each zipper which includes diameter, length and piece number of that particular section.

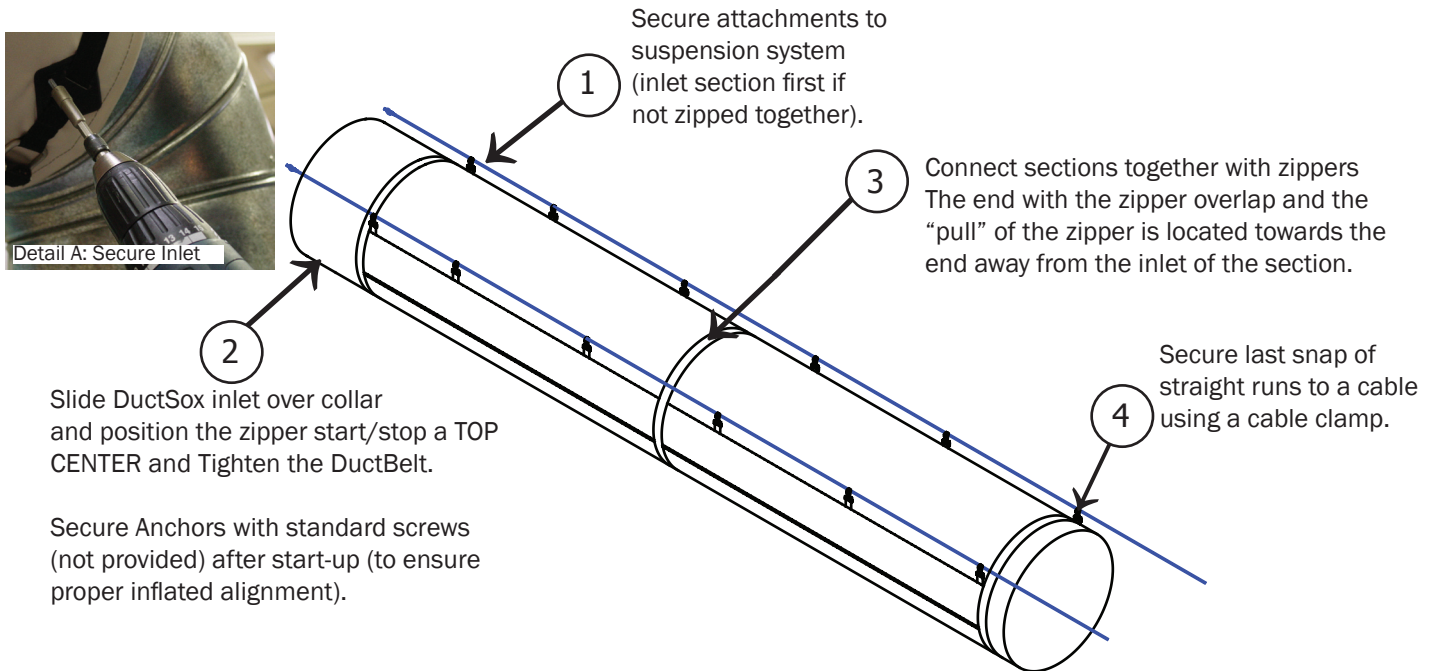

# 4

## START UP

Turn on the AHU and inflate DuctSox System. Check all snaps and sections to ensure system is inflating properly. If required - move snaps to eliminate pucking at binding locations. If lengths do not fit properly - contact the factory to coordinate rework to ensure proper fit.

Once system is properly adjusted, deflate the system, pull the last snap in each straight section and secure tension using cable clamp to cable (will reduce inflation "popping"). If the system includes elbows - secure the last snap before elbow(s).

**\*Cable clamps are provided to secure snaps.**

Failure to install DuctSox systems correctly can void warranty.



System must be balanced to design CFM and static pressure immediately after installation. Most Duct-Sox systems include a zipper at the inlet location for easy access to monitor flow.

If the fabric is fluttering after balancing, please contact the factory immediately. Solutions to the fluttering include adjusting the Adjustable Flow Device (AFD), adding AFD's or other tasks that would result in laminar airflow.

## **FILTRATION / DUCTSOX FINAL FILTER**

If included, a DuctSox Final Filter will be provided assemble with the DuctSox system and should be positioned at the first zipper at the inlet of the DuctSox run. If the Equipment / fabric duct is going to be running during construction, a Merv 8 construction filter may be helpful in reducing build up of dust / dirt.

If the system becomes dirty/soiled during installation, please coordinate a proper cleaning prior to completion. Exterior surface dirt can - most frequently - be blown off using a combination of a brush and compressed air.

## **LAUNDRY INSTRUCTIONS**

### **Sedona-Xm, TufTex, Verona, DuraTex, Microbe-X & Stat-X fabrics:**

- Remove system and break down into sections
- Turn Soiled side out, soak in cold water for 30 minutes
- Wash cold gentle cycle
- Rinse thoroughly (repeat cycle if water / DuctSox still soiled)
- Drip-dry or no heat tumble dry

### **EkoTex fabric (cannot launder)**

- Remove DuctSox, spray clean with hose / water source.

If any questions arise regarding the installation of your DuctSox system, please do not hesitate to consult your support team at (866) DuctSox (382-8769).

**DUCTSOX**<sup>®</sup>  
*Fabric Air Dispersion Products*

9866 Kapp Court • Peosta, IA 52068  
Ph: 866-382-8769 • Fax: 563-588-5330

[www.ductsox.com](http://www.ductsox.com)