

Thank you for selecting a DuctSox ventilation system. This guide should be helpful for installing Surface Mount Suspension Systems. Sections of fabric will be labeled, assembled, bagged, and boxed for shipping. More complicated systems will include a CAD detail of the system identifying what is in each package.

Overview

Inventory

The first step on any installation project is to check the order and familiarize yourself with what needs to be installed. Typically the best way to do this is to review the drawings of the project, including the CAD detail. If the drawings have not been supplied or the system is a retro-fit to existing equipment, we suggest reading through this manual completely to properly educate yourself on field installation. Please make sure you have all boxes.

Shipping

Depending on the size of a project or order, a DuctSox system will be shipped by common courier in a single brown box or several boxes. Larger orders will be shipped in crates by a common freight carrier. Each DuctSox length should be packaged into individual plastic bags and labeled according to size and number of pieces. Other markings or labeling may also be incorporated for larger or more complicated systems.

Unpackaging

Inspect shipment carefully matching contents with packing slip information. Account for everything. Note any missing or damaged pieces listed on the Bill of Lading before accepting the shipment in order to facilitate a claim for shipping damage with the carrier.

Labeling

Each DuctSox section will be marked with the size and section number either inside the belt of the inlet or on a tag sewn inside the tube near the zipper. The marking shall be the diameter, section length and total length. If custom labeling has been used, locate an identification sheet that will be included with the delivery.

Equipment Required:

- Drill
- Rivet gun
- Screwdriver
- Tape measure
- Marker or pencil

Component Details

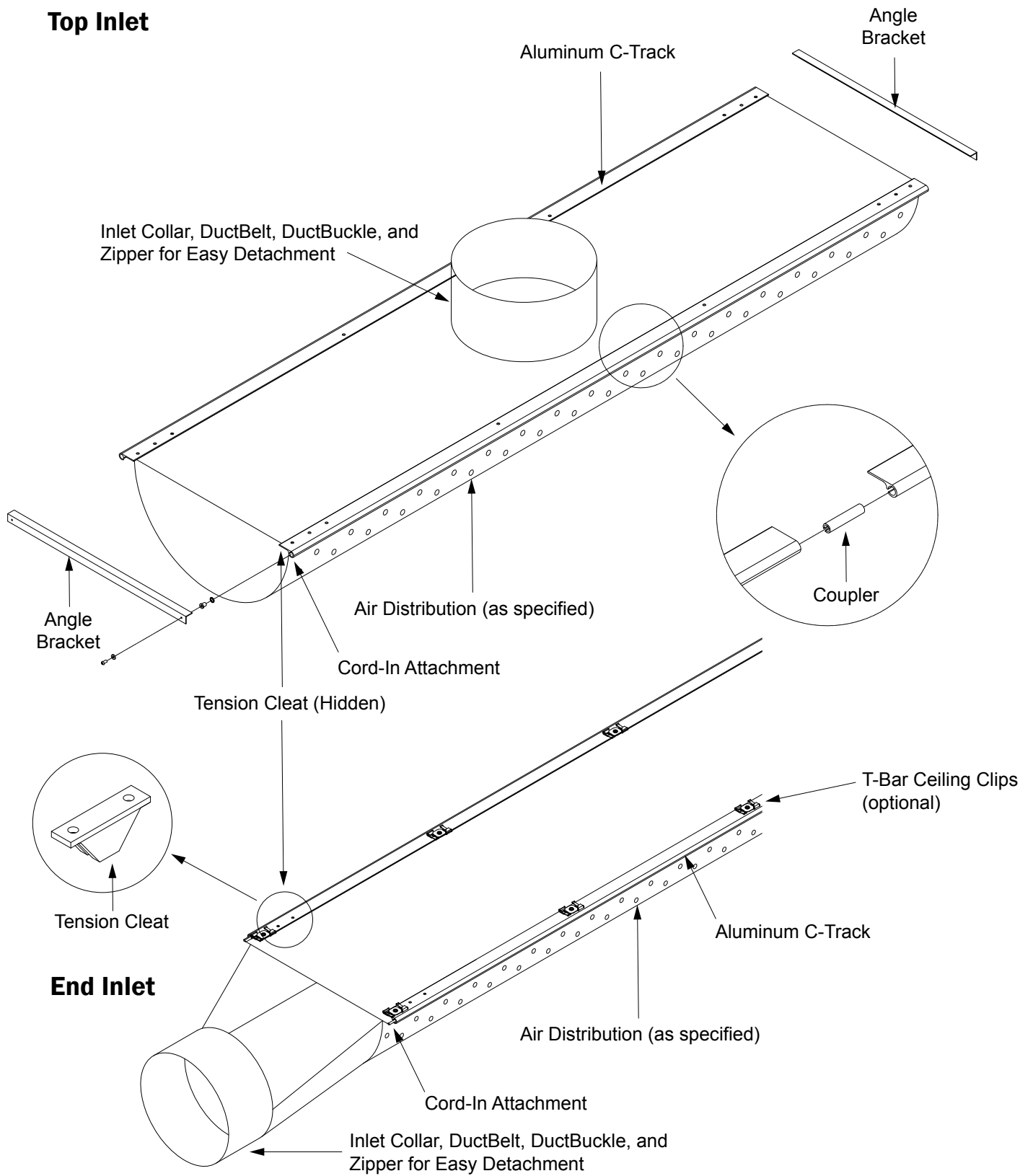

Installation Steps

1. Review materials in box, including the CAD drawing and product placement.
2. Prepare metal inlet collar for fabric connection.
3. Mark placement of track.
4. Install track, couplers, and cleats.
5. Install inlet belt to metal inlet collar.
6. Slide DuctSox onto track.
7. Tighten cleats.
8. Install angle bracket.
9. Balance airflow.

Step 1

Review materials in box, including the CAD drawing and product placement. READ INSTRUCTIONS THOROUGHLY BEFORE BEGINNING.

Step 2

Prepare metal inlet collar for fabric connection.

- Confirm inlet air supply location (top or end).
- Confirm inlet air supply size.
- DuctSox inlets are manufactured $1/2$ " larger than specified to fit over metal inlet collar.
- Collar length should be 6"–10" for secure fabric attachment.
- Edge guard (provided) should be installed on the edge of the metal collar to reduce fabric wear on metal edge.

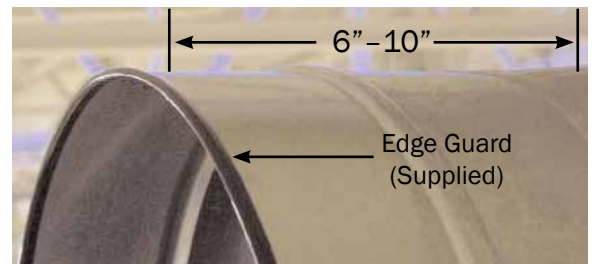

Step 3

Mark placement of track. The width of the track is the diameter of the DuctSox minus two inches. For example, for a 12 inch diameter DuctSox, the width of the track should be 10 inches.

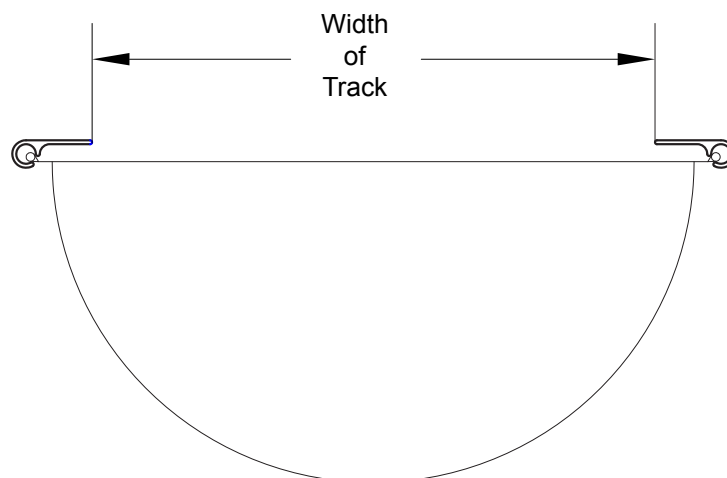

Step 4

Install track, couplers, and cleats. The D-Shape System includes anodized aluminum track, couplers, and suspension components. T-Bar clips are available for a variety of T-Bar types for easier installation. NOTE: If fittings are used, see CAD drawing provided.

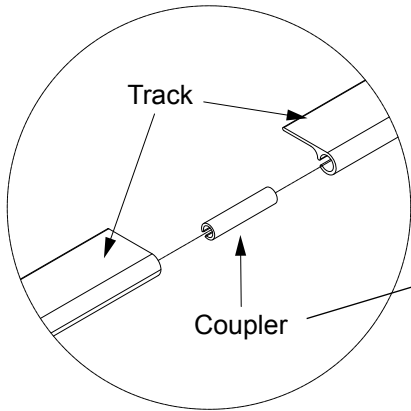

Track: 8' sections, radius sections available.

Track Mount: Secure track to surface every 3 to 4 feet along track using a screw or T-Bar clip with rivet.

Coupler: Friction fit, align coupler opening with track opening, install as shown.

T-Bar Clips with Rivet: Mount Flush Track to T-Bar ceiling. Include 1 per 4 feet of track. Standard type for 1" T-Bar rail (others available).

Cleat: Install 2 inches before the end of the duct with Phillip's screws provided. The long slope of the cleat should point towards the center of the DuctSox. See below drawing for cleat locations.

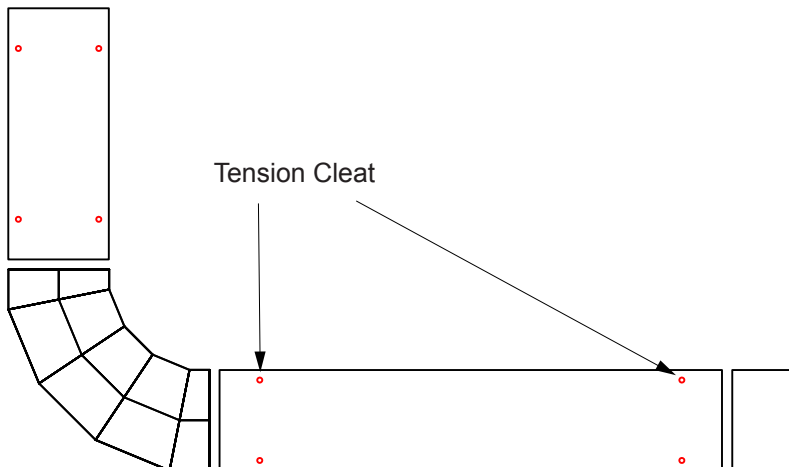
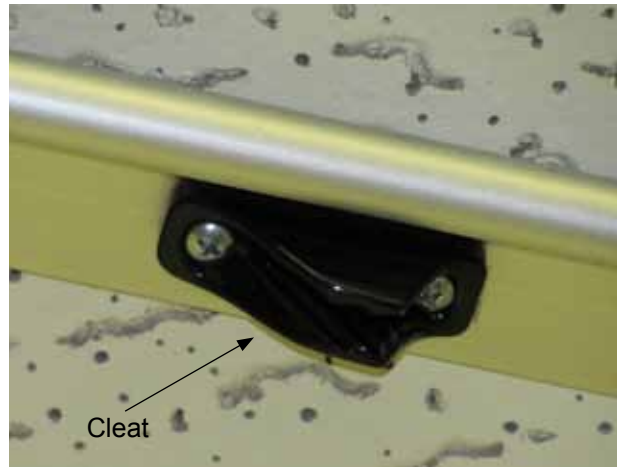

Step 5

Install inlet belt to metal inlet collar.

Step 6

Unzip fittings, if applicable. Slide DuctSox onto track. Zip fittings together, if applicable.



Fittings (if applicable)



Step 7

Tighten cleats. Pull cord tight and lock in cleat.

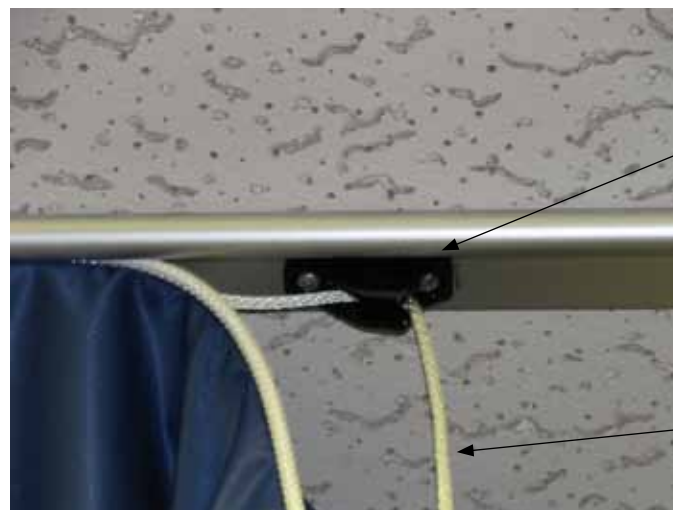

Cleat

Pull tight and lock

Step 8

Install angle bracket.

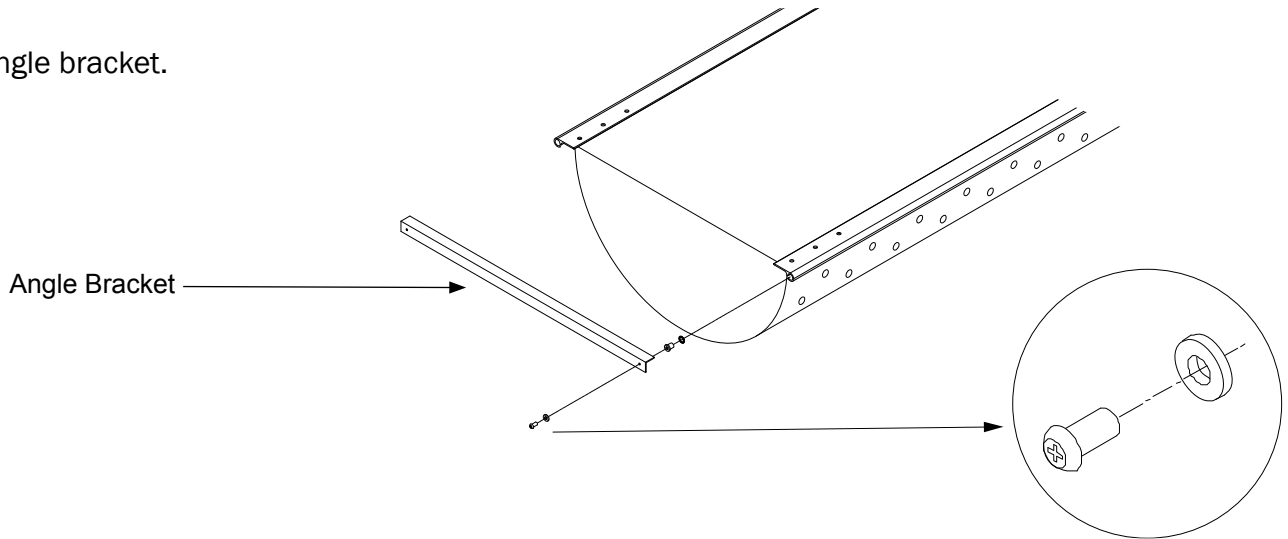

Step 9

Balance airflow. System must be balanced to specified CFM and static pressure immediately after installation. Most DuctSox Systems include a zipper at the inlet location for easy access to monitor flow.

Laundering Instructions

Sedona-Xm, TufTex, Verona, DuraTex, Microbe-X, Rx, and Stat-X fabrics:

- Remove system and break down into sections
- Turn soiled side out, soak in cold water for 30 minutes
- Wash cold, gentle cycle
- Rinse thoroughly (repeat cycle if water/DuctSox still soiled)
- Drip dry or no heat tumble dry



If any questions arise regarding the installation of your D-Shape System, contact us.

866-DuctSox or 866-382-8769

DUCTSOX[®]
Fabric Air Dispersion Products

9866 Kapp Court ■ Peosta, IA 52068
Ph: 866-382-8769 ■ Fax: 563-588-5330
www.ductsox.com